

# STICHT

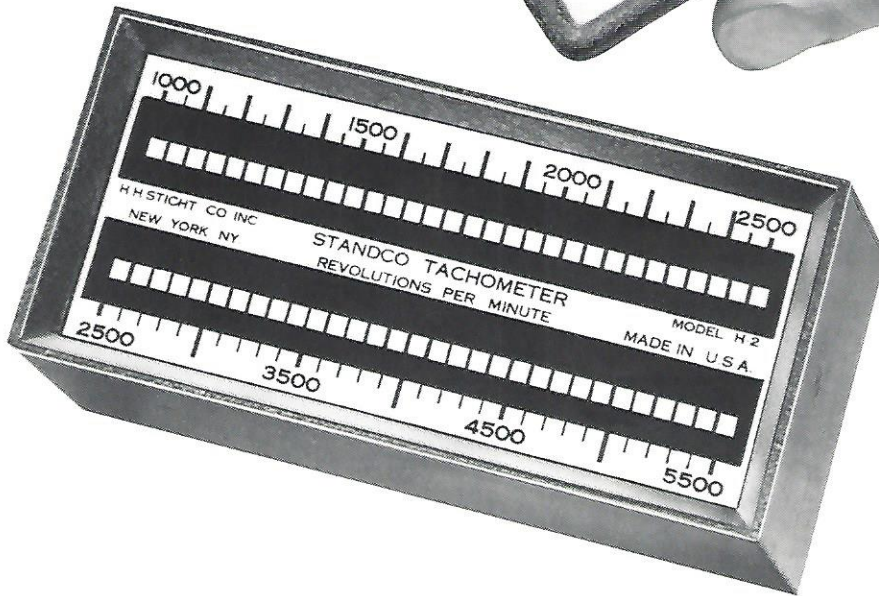
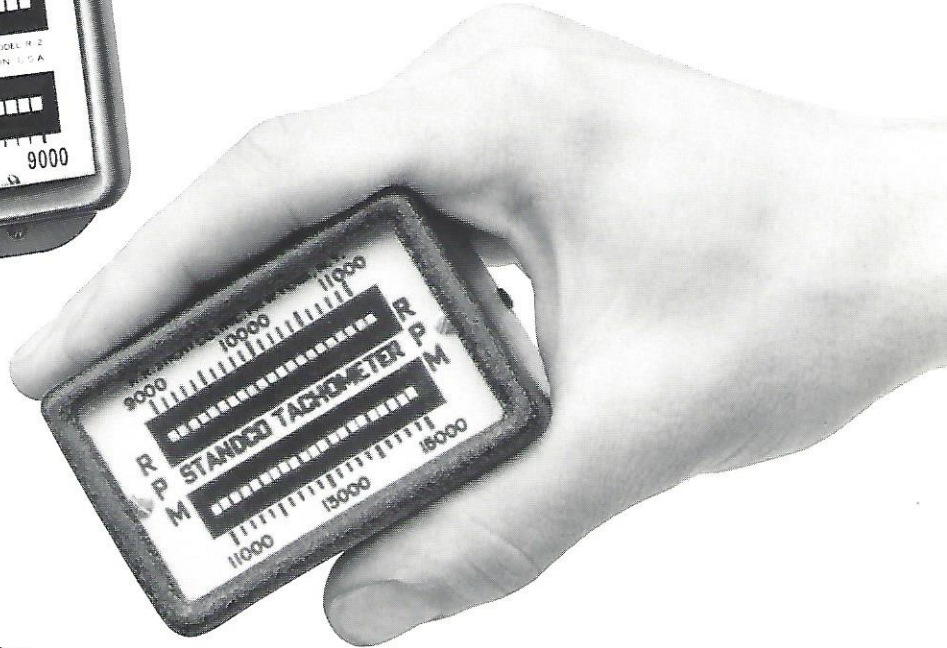
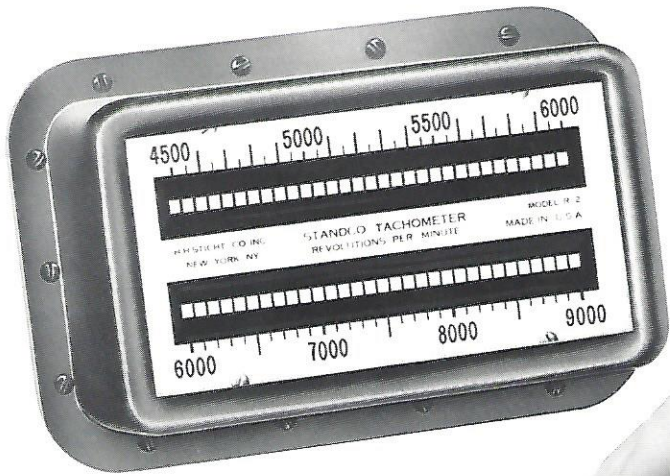

## STANDCO™ VIBRATING REED TACHOMETERS

MEASURE ROTATIONAL SPEED WITHOUT  
CONTACTING MOVING PARTS

# TYPE R STATIONARY VIBRATING REED TACHOMETERS

These vibrating reed tachometers are designed for permanent mounting. They are fitted with lugs to suit the mounting brackets shown below.

Enclosed in a gasketed, splash proof case, these instruments have a white face with black markings.

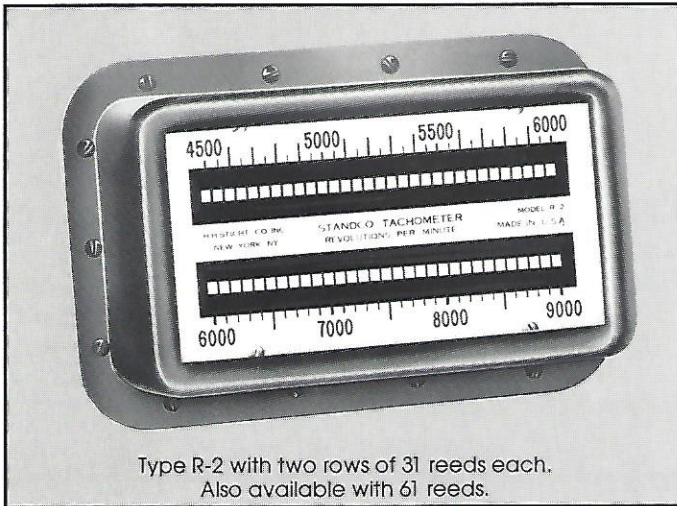

Type R-2 with two rows of 31 reeds each. Also available with 61 reeds.

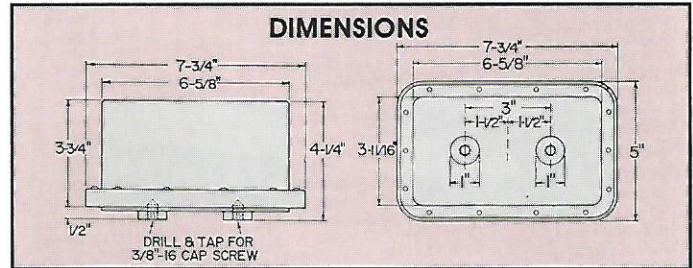

## TYPE R-1. ONE ROW OF 31 REEDS

OUR CAT. NO.	NORMAL SPEED R.P.M.	RANGE R.P.M.	INTERVAL BETWEEN REEDS R.P.M.
8101	1200	900-1500	20
8102	1500	1200-1800	20
8103	1800	1425-2175	25
8104	3000	2250-3750	50
8106	3600	2850-4350	50
8107	4000	3250-4750	50
8108	4250	3500-5000	50
8109	4550	3800-5300	60
8110	4800	4050-5550	60
8111	5000	4250-5750	50
8112	5250	4500-6000	50
8113	5500	4000-7000	100
8114	5550	4800-6300	50
8115	6000	5250-6750	50
8116	6000	4500-7500	100
8117	6500	5000-8000	100
8118	7200	5700-8700	100
8119	8000	6500-9500	100
8120	10000	8500-11500	100
8121	10000	9000-12000	100
8122	12000	9000-15000	200
8123	13500	12000-15000	100
8124	15000	12000-18000	200
8125	18000	15000-21000	200
8126	20000	18000-24000	200

## BRACKET NO. 8400 -45° MOUNTING

Can be used with Type H and Type R tachometers

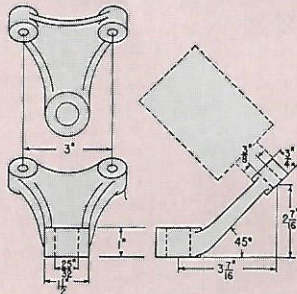
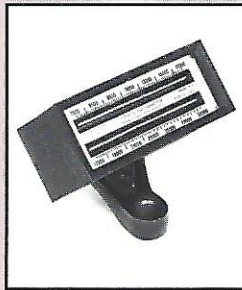

## TYPE R-2. TWO ROWS OF 31 REEDS EACH

8230	...	{ 900-1200 1200-1800 }	{ 10 20 }
8231	...	{ 1000-1600 1600-2200 }	{ 20 20 }
8232	...	{ 1250-2000 2000-2750 }	{ 25 25 }
8233	...	{ 1300-1900 1900-2650 }	{ 20 25 }
8234	...	{ 1500-2250 2250-3000 }	{ 25 25 }
8235	...	{ 1750-2500 2500-4000 }	{ 25 50 }
8236	...	{ 2250-3000 3000-4500 }	{ 25 50 }
8237	...	{ 2000-3500 3500-5000 }	{ 50 50 }
8239	...	{ 1000-2500 2500-5500 }	{ 50 100 }
8243	...	{ 3000-4500 4500-6000 }	{ 50 50 }
8244	...	{ 3300-4800 4800-6300 }	{ 50 50 }
8246	...	{ 3000-4500 4500-7500 }	{ 50 100 }
8248	...	{ 4500-6000 6000-9000 }	{ 50 100 }
8250	...	{ 6000-9000 9000-12000 }	{ 100 100 }
8251	...	{ 9000-12000 12000-18000 }	{ 100 200 }
8252	...	{ 18000-24000 24000-30000 }	{ 200 200 }
8253	...	{ 15000-21000 21000-30000 }	{ 200 300 }

## BRACKET NO. 8401 - ROD MOUNTING

Can be used with Type H and Type R tachometers

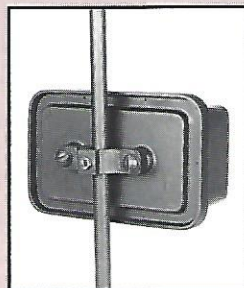
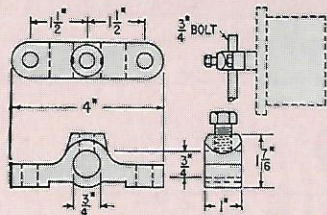

NOTE: All dimensions and weights shown are approximate.

Available with NIST certification

# STICHT

## TYPE H HAND HELD VIBRATING REED TACHOMETERS

These units are designed to be held against the housing of equipment being checked. They can

also be permanently mounted if desired with 8400 and 8401 brackets. Carrying cases are available.

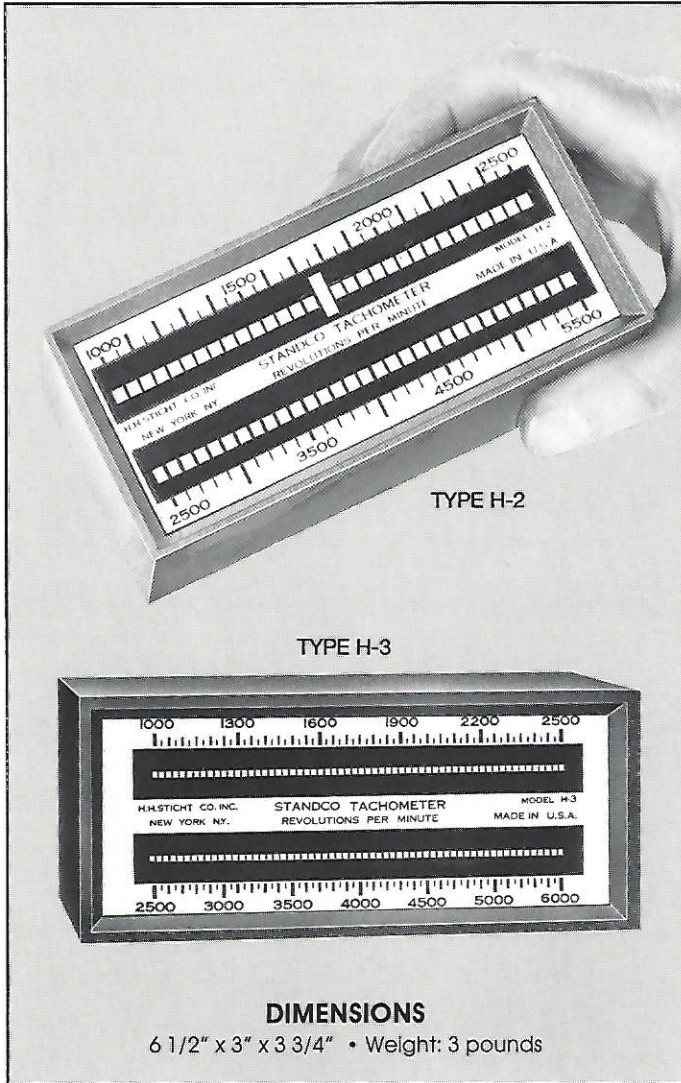

TYPE H-2 WITH 2 ROWS OF 31 REEDS EACH			
OUR CAT. NO.	NORMAL SPEED R.P.M.	RANGE R.P.M.	INTERVAL BETWEEN REEDS R.P.M.
6228-C	...	{ 600-900 900-1500 }	{ 10 20 }
6230	...	{ 900-1200 1200-1800 }	{ 10 20 }
6231	...	{ 1000-1600 1600-2200 }	{ 20 20 }
6234	...	{ 1500-2250 2250-3000 }	{ 25 25 }
6235	...	{ 1750-2500 2500-4000 }	{ 25 50 }
6236	...	{ 2250-3000 3000-4500 }	{ 25 50 }
6237	...	{ 2000-3500 3500-5000 }	{ 50 50 }
6239	...	{ 1000-2500 2500-5500 }	{ 50 100 }
6240	...	{ 2500-4000 4000-5500 }	{ 50 50 }
6241	...	{ 2750-4250 4250-5750 }	{ 50 50 }
6242	...	{ 1500-3000 3000-6000 }	{ 50 100 }
6243	...	{ 3000-4500 4500-6000 }	{ 50 50 }
6245	...	{ 2200-3700 3700-6700 }	{ 50 100 }
6246	...	{ 3000-4500 4500-7500 }	{ 50 100 }
6248	...	{ 4500-6000 6000-9000 }	{ 50 100 }
6249	...	{ 5500-7000 7000-10000 }	{ 50 100 }
6250	...	{ 6000-9000 9000-12000 }	{ 100 100 }
6251	...	{ 9000-12000 12000-18000 }	{ 100 200 }
6252	...	{ 18000-24000 24000-30000 }	{ 200 200 }
6253	...	{ 15000-21000 21000-30000 }	{ 200 300 }

TYPE H-3 WITH 2 ROWS OF 61 REEDS EACH			
6355	1st Row	{ 1000-2500 2500-5000 }	{ 25 50 }
	2nd Row	{ 5000-6000 }	{ 100 }
6356	1st Row	{ 1500-3000 3000-4500 }	{ 25 50 }
	2nd Row	{ 4500-7500 }	{ 100 }
6360	1st Row	{ 3000-6000 6000-12000 }	{ 50 100 }
	2nd Row		
6357	1st Row	{ 6000-12000 12000-24000 }	{ 100 200 }
	2nd Row		
6358	1st Row	{ 7500-10000 10000-17000 }	{ 100 200 }
	2nd Row	{ 17000-23000 23000-30500 }	{ 200 250 }
6359	1st Row	{ 600-1200 1200-3000 }	{ 25 50 }
	2nd Row	{ 3000-4000 4000-8000 }	{ 50 100 }

TYPE H-1. ONE ROW OF 31 REEDS			
OUR CAT. NO.	NORMAL SPEED R.P.M.	RANGE R.P.M.	INTERVAL BETWEEN REEDS R.P.M.
6101	1200	900-1500	20
6103	1800	1425-2175	25
6104	3000	2250-3750	50
6106	3600	2850-4350	50
6107	4000	3250-4750	50
6111	5000	4250-5750	50
6115	6000	5250-6750	50
6116	6000	4500-7500	100
6117	6500	5000-8000	100
6118	7200	5700-8700	100
6119	8000	6500-9500	100
6122	12000	9000-15000	200
6124	15000	12000-18000	200
6126	20000	18000-24000	200
6127	25000	21000-30000	300

NOTE: All dimensions and weights shown are approximate.

Available with NIST certification

# TYPE D DWARF VIBRATING REED TACHOMETERS

Because of their small size, these hand meters are easy to carry in toolbox or pocket. Mounting

brackets are available if permanent installation is preferred. Also available is a carrying case



TYPE D-1 WITH ONE ROW OF 21 REEDS		
OUR CAT. NO.	RANGE R.P.M.	INTERVAL BETWEEN REEDS R.P.M.
9160	1000-1500	25
9161	1500-2000	25
9162	1700-2200	25
9159	1000-2000	50
9158	1000-3000	100
9163	2000-3000	50
9164	3000-4000	50
9171	3000-5000	100
9165	3400-4400	50
9172	3500-5500	100
9166	4000-5000	50
9173	4000-6000	100
9167	5000-7000	100
9168	5200-7200	100
9169	7000-9000	100
9157	7000-11000	200
9170	9000-13000	200
9174	12000-16000	200

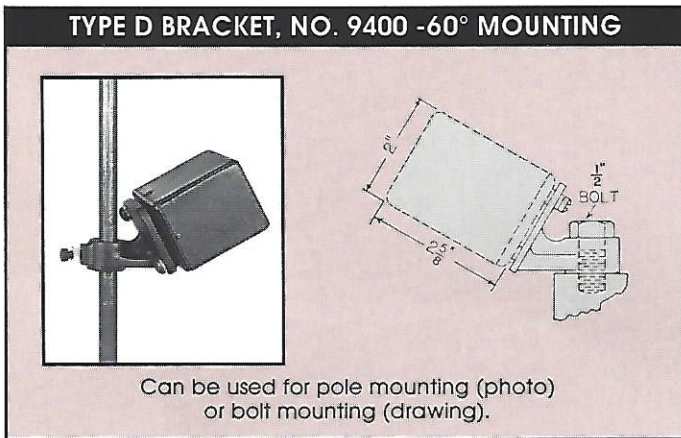

TYPE D-2 WITH TWO ROWS OF 21 REEDS EACH			
9275	{ 1000-2000 2000-4000 }	{ 50 100 }	}
9276	{ 1000-1500 1500-2000 }	{ 25 25 }	}
9282	{ 1500-3500 3500-5500 }	{ 100 100 }	}
9277	{ 2000-3000 3000-4000 }	{ 50 50 }	}
9283	{ 1000-3000 3000-6000 }	{ 100 150 }	}
9281	{ 2500-4500 4500-6500 }	{ 100 100 }	}
9278	{ 4000-5000 5000-7000 }	{ 50 100 }	}
9284	{ 3500-5500 5500-7500 }	{ 100 100 }	}
9286	{ 2000-4000 4000-8000 }	{ 100 200 }	}
9279	{ 5000-7000 7000-9000 }	{ 100 100 }	}
9285	{ 7000-9000 9000-11000 }	{ 100 100 }	}
9280	{ 9000-11000 11000-15000 }	{ 100 200 }	}

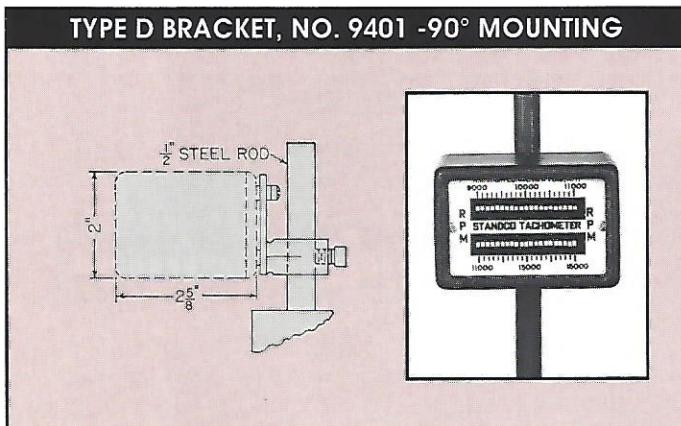

NOTE: All dimensions and weights shown are approximate.

Available with NIST certification

# STICHT

## STANDCO™ VIBRATING REED TACHOMETERS

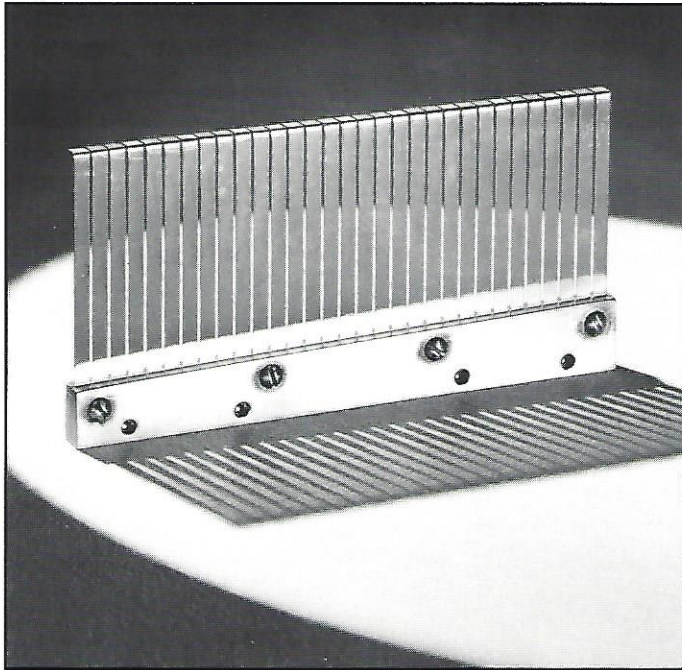

### HOW THEY WORK

Vibrating reed tachometers measure rotational speed by picking up the rate of vibration of all types of enclosed equipment with one rotating element. When the meter is placed in contact with the housing of the equipment, accurately calibrated reeds, tuned to selected frequencies of vibrations, indicate the speed in RPM on the meter's scale. They require no power so they can be used in hazardous areas.

Housings are constructed of aluminum alloy with a semi-gloss and wrinkled black enamel finish.

Standco Vibrating Reed Tachometers are available in hand-held models or stationary models which can be permanently mounted on the housing. They can be ordered in a wide number of ranges for speeds between 600 and 30,500 RPM.

### FEATURES

- Accurate - 0.5% of rated frequency. Individual reeds, 0.3% at room temperature.
- Economical - require no tips, flexible shafts, gears or other drive mechanism. No oiling or maintenance.
- Durable - simple operating principle means less wear and long life.
- Safe - no contact with high speed shafts required.
- No load imposed - can be used on the smallest equipment.

### CUSTOM RANGES AND OPTIONS

In addition to the ranges indicated for each tachometer shown, Herman H. Sticht can provide special ranges to suit your special needs. Amplitude stimulators can also be built into the instruments to enhance readability.

### HOW TO READ VIBRATING REED TACHOMETERS

The following is a typical scale of a Standco Vibrating Reed Meter with a range from 1425 to 2175 RPM and an interval between reeds of 25 RPM.

#### EVEN PATTERN

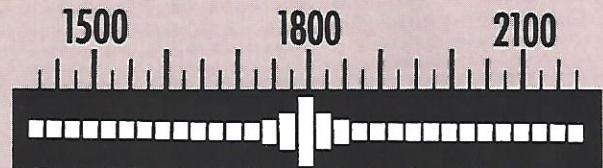

One reed has maximum amplitude while adjoining reeds have less but equal amplitude. Speed is 1800 RPM

#### TWO REEDS WITH SAME AMPLITUDE

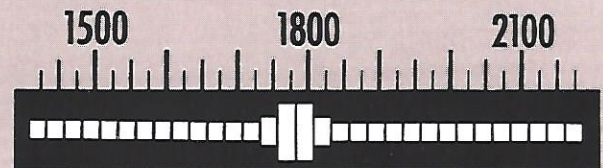

Two adjoining reeds at 1800 RPM and 1775 RPM have the same amplitude. Speed is halfway between the two reeds, 1788 RPM.

#### UNEVEN PATTERN BELOW 1800

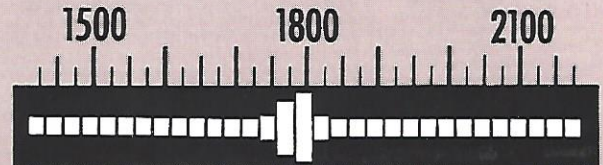

One reed has maximum amplitude at 1800 RPM. Adjoining reed 1775 vibrates almost as much. Other adjoining reeds below 1800 taper off proportionately. Speed is one quarter between 1800 and 1775, 1794 RPM.

#### UNEVEN PATTERN ABOVE 1800

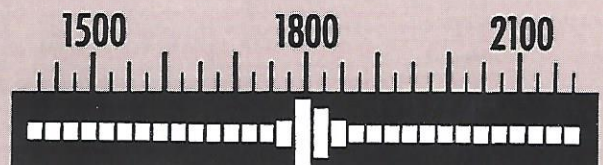

This is the same pattern as above but on the high side of 1800. Speed is one quarter between 1800 and 1825, 1806 RPM.